

NanoCarb^{RCOM}

NCBARRIER[®]

Model: NCB-3CN
Model: NCB-3CA

NanoCarb Inc.

954a Labelle, St-Jerome, Quebec, Canada J7Z 5M8

Tel: (450) 565-8408 * Fax: (450) 565-4691

E-mail: info@nanocarb.com

Web Site: <http://nanocarb.com>

ADVANCED
WIDE
SPECTRUM
CARBON
MONOBLOCK
WATER
PURIFICATION
SYSTEM

Rated
at 0.45
micron
absolute



Installation, Maintenance & Sterilization

Quality, simplicity & security...

Congratulations on your purchase of the **NCBarrier3** NanoCarb - Advanced Wide Spectrum Carbon MonoBlock Water Purification System. Choosing the **NCBarrier3** is well founded because it incorporates the best and highest quality components currently available on the market, in order to ultimately guarantee you the most advantageous performance and quality possible.

Securing a confident and long-term purified water source is more and more on the minds of everyday homeowners. You have undoubtedly looked into, or even tried, other alternatives, and your choice kept coming back to the simplicity and durability of water purification and its long-term benefits.

The following manual explains the **NCBarrier3**

system installation, maintenance, and above all, the sterilization method used to keep the faucet system clean. Please read it before attempting to install your **NCBarrier3** unit so you may take full advantage of the system for many, many years to come.

Don't hesitate to call your dealer, or us, if you require any additional information. It's always a pleasure to hear from you.

Enjoy your **NCBarrier3** pure water system!

The Management - NanoCarb Inc.

If you only had one filter to trust...

...trust NanoCarb!

NCBarrier³ Installation Diagram

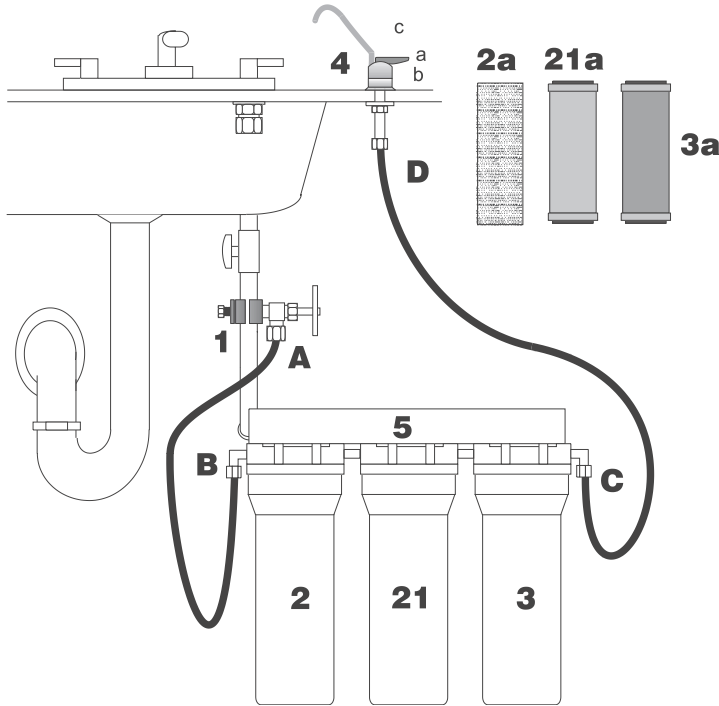

Legend for the NanoCarb NCBarrier³ Diagram

In this manual, we will refer to specific system components as illustrated in the Installation Diagram on page 2 using bold italic characters in brackets (Example: **(1)**, **(A)**, etc.)

Item	Description
1	Self-piercing needle valve on inlet pipe
A	Tube connection to needle valve
2	Pre-filter housing. (See 2a)
21	Pre-filter housing. (See 21a)
B	Connection to pre-filter inlet
2a	Sediment prefilter -1mic.nom.-10"
21a	C. block prefilter -1mic.ab. - 10"
3	NanoCarb filter housing. (See 3a)
C	Connection to NanoCarb housing outlet
3a	NanoCarb NC-254 filter
D	Connection of pure water faucet.
4	Pure water faucet and 3 position handle:
	a Closed
	b Open on water demand
	c Open permanently
5	NCBarrier3 wall mounting bracket
6	Filter housing wrench (not shown)

SPECIFICATIONS

NANOCARB media type	NanoCarb Mono Block
Feed Water Type	Water must be clear and free of silt.
Sediment pre-filter	Rated at
Spun Polypropylene Depth Filter	1 micron nominal - 10"
Carbon block pre-filter	Rated at
High quality extruded radial flow	1 micron absolute - 10"
NanoCarb NC-254	Rated at
Advanced Carbon Mono Block Filter	0.45 micron absolute - 10"
NanoCarb NC-254 Radial Depth	7/8"
Pure Water	0.34 to 0.45 gpm @ 56 PSI
Production Capacity*	(1.3 to 1.7 lpm) @ 56 PSI
Feed Water Temperature - Maximum	104 deg. F (40 deg C.)
Feed Water Pressure - Maximum	145 psi (10 bar)
Feed Water Limitations**	PPM=Parts per million
Hardness	15 grains per gallon or 260 ppm
Total Dissolved Solids (TDS)	1200 PPM
Ferrous Iron	0.1 PPM max.
Ferric Iron	0 PPM
pH	5.5 to 9.0
Manganese	0.01 max.
Hydrogen Sulfide (H ₂ S)	0 PPM
Tannin***	0 PPM
Turbidity	Less than 3 UTN

* The pure water production range indicated above is based on feed water quality meeting the Feed Water Limitations indicated above.

** Filter life will vary depending on actual water conditions and the percentage of particles contained in the feed water that are between 0.25 and 0.45 micron absolute.

*** Tannin is evident as a yellow tint to water which is due to the decomposition of vegetable matter. This is very prevalent in well water but more present in lake waters. Tannin will pass through any prefiltration stage and quickly block the NanoCarb NC-254 filter, hence you must consider pretreating the water for tannin using ion exchange anion resin or other acceptable method.

Actual filter life will be evident after the first life cycle, after which you may develop your own personal filter change frequency.

You may possibly increase NanoCarb NC-254 filter life by using a different pre-filter. In situations where the NanoCarb NC-254 filter is being saturated after only 2-4 months, it may be more advantageous to use a low cost carbon block or KDF pre-filter in the 1 micron nominal range, instead of the Spun Polypropylene Depth Filter (2).

How the NCBarrier³ works

Feed water enters via the self-piercing needle valve (1), and enters the first pre-filter (2), where particles bigger than 1 micron nominal are contained, then exits the first pre-filter to enter the second pre-filter (21), where particles bigger than 1 micron absolute are contained, then exits the second pre-filter to enter the NanoCarb filter housing (3), where water passes through the carbon matrix and exits the filtration unit via the pure water faucet (4) which is mounted on the kitchen sink. A wall mounting bracket (5) enables installation of the filter unit on either side under the sink, while some people will elect to simply let the filtration unit stand on its own.

The NCBarrier³ Water Purification System, combined with a comprehensive filter replacement (2a),(21a) and (3a) and added to a system sterilization program, will produce exceptional pure water quality for years and years.

Installation

Installation of your **NCBarrier³** system can be quickly accomplished by following these instructions. We do however recommend that you have some experience in plumbing procedure. If you feel uncomfortable installing the system, please call a plumber or your **NCBarrier³** dealer, or a knowledgeable friend.

List of components

Description	Qty.
NCBarrier ³ Module	1
Sediment pre-filter	1
Carbon Block pre-filter	1
NanoCarb NC-254 filter	1
Chromed faucet with accessories	1
Self-piercing needle valve with acc.	1
Filter wrench	1
10 feet of flexible tubing (2 x 5 ft.)	1

You will need the following tools

- Electric drill
- Metal drill bits 1/8", 1/4" et 1/2"
- Star screwdriver (Phillips)
- Pliers or adjustable wrench or 5/16" key
- Scissors and round file

NanoCarb Resurfacing

Should the NanoCarb filter (**3a**) become prematurely saturated, which is evident by a dramatic reduction in water flow, some users have been known to resurface the NanoCarb filter in order to extend the service life.

Close needle valve (**1**) and open the water faucet (**4c**) to release internal pressure. Unscrew the NanoCarb filter housing (**3**) using the filter wrench and remove the NanoCarb filter.

Slide off the outer netting and remove the sheeting off of the NanoCarb filter.

Scrape the surface of the filter with the back of a knife to remove a thin layer of carbon material. Rinse the filter exterior. Slowly pour a small amount of chlorine bleach into the top opening of the NanoCarb filter.

Install the filter back into the housing and screw the housing back onto the module. Close the pure water faucet and open the needle valve. Open the pure water faucet until the chlorinated water starts coming out of the faucet.

Let the chlorine water sit in the faucet for at least 30 minutes. Open the faucet for about 2 minutes to clear the chlorine from inside the filter. The system is ready for reuse. Repeat as required. Replace the filter if this does not increase flow.

Connecting the flexible tubing

To install your **NCBarrier³** system, you will have to connect 2 lengths of tubes at 4 points on the system. Depending on your system, there are up to three types of tube connections which could be required to install your system:

1: Brass nut, plastic ferrule and insert.

Tubes going to the faucet (**4**) and needle valve (**1**):

A) Slide brass nut (**1**) on tube with thread facing tube end. B) Slide ferrule (**2**) onto the tube with the large incline pointed towards the tube end. C) Insert the plastic insert (**3**) into the tube end. D) Slide the tube end into the fitting. E) While holding the tube in the fitting, slide the brass nut and ferrule towards the fitting threads. Tighten the brass nut by hand and then do one turn with pliers or adjustable wrench.

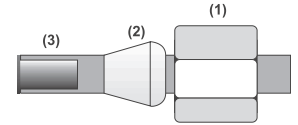

2: Plastic nut and insert.

Tube connection destined to the optional holding tank shut-off valve. (Not shown)

A) Slide plastic nut (**1**) on tube with thread facing tube end. B) Insert the plastic insert (**2**) into the tube end. C) Slide the tube end into the fitting. D) While holding the tube in the fitting, slide the plastic nut towards the fitting threads. Tighten the plastic nut by hand.

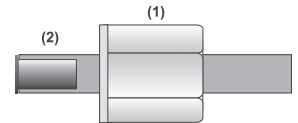

3: Push-in connections.

Tube connections destined to inlet and outlet of the filter system.

1) Push tube into the fitting until it is firmly seated.

2) Pull slightly on tube to ensure the retaining ring has locked.

3) To remove the tube, hold in the retaining ring and pull on the tube.

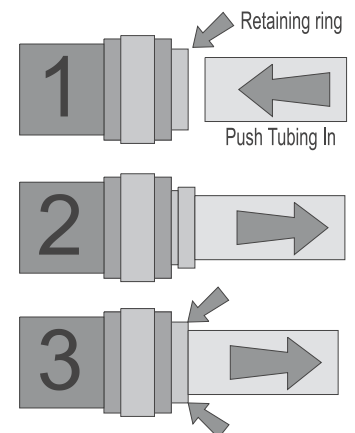

Installation location

The system is generally installed under the kitchen sink in such a way as to be easily accessible for service while being discreetly positioned to optimize the remaining storage space.

Cut the tube lengths long enough for you to move the unit, from under the sink to the kitchen counter for easy filter replacement. Use scissors to cut the tubing to the appropriate lengths required.

You can also install and connect the inlet to the unit in the basement and run a tube up to the kitchen sink.

Installation of the faucet (4)

For Stainless Steel sinks only;

A) Identify the location you will drill on the sink. Make sure there is room under the sink at the chosen point so you can place the washer (4).

B) Make a mark at the drill point.

C) Drill a 1/8" hole, then a 1/4" hole, and finally a 1/2" hole. Be careful not to slide with the drill. File the hole to take off any sharp edges.

D) Place the wide thin plastic washer (3), the chromed washer (2) and the small plastic washer (1) over the hole. Pass the long threaded stem of the faucet through the washers and the hole.

E) Maintain the desired faucet angle, and slide the large metal washer (4) and the lock washer (5) over the threads and screw on the bolt (6) all the way up by hand.

F) Check the faucet angle again and then tighten the bolt (6) with pliers or an adjustable wrench. Make sure the faucet does not move from your chosen angle. Do not use pliers on the faucet chromed body to avoid scratching it.

G) Connect the appropriate tube length to the faucet thread using a brass nut (9), a plastic ferrule (10) and a plastic insert (11). Hand tighten then turn one time with pliers or adjustable wrench.

H) Connect to other end of the tube to the filter unit at point (C) using a plastic nut and insert.

How the 3 position faucet handle works.

- Z Open permanently (stays open by itself)
- X Closed position
- Y Open on demand. Closes when the handle is released.

ENAMEL COATED SINKS: Given the high priced nature of such sinks, we highly recommend that you have this hole drilled by a certified professional, or maybe, locate the faucet beside the sink, on the counter. Drilling may cause enamel to chip if done incorrectly.

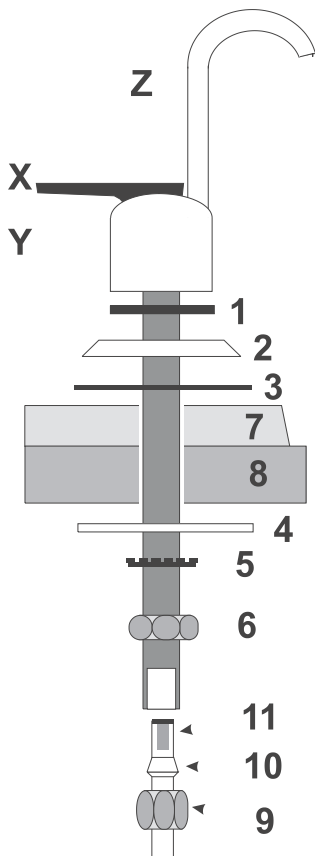

Installation of the self-piercing needle valve (SPNV) (1)

ATTENTION: The SPNV is installed on the **COLD WATER LINE ONLY**. If you don't know which pipe is the cold one, turn on both water faucets and feel the pipes under the sink. Do not use the pipe which gets hot.

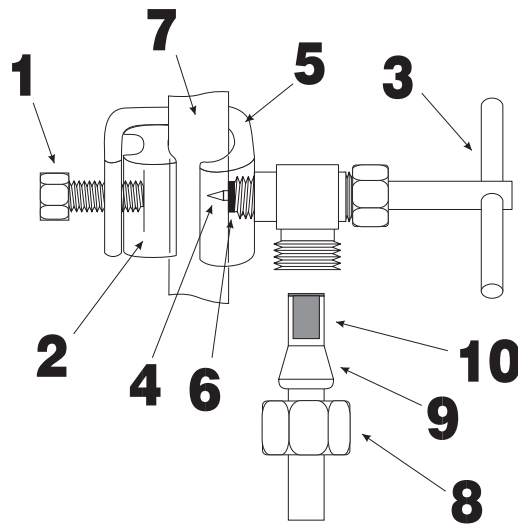

Installing on hot water line will damage the filters.

Feed water to your **NCBarrier³** system is via the SPNV. This valve is adaptable to the 1/2" copper pipe under the kitchen sink. Make sure that the pipe provides ample clearance to secure the SPNV. Proceed as follows:

- 1) Closed the main house valve.
- 2) Turn on hot and cold water taps to release pressure in the piping system. Also turn on taps on higher floors if any.
- 3) If possible, turn on hot and cold taps in the basement. This will empty the water lines on the first floor to prevent any leaks.
- 4) Unscrew the bolt (1) to release the adapter shank (2) from the valve body (5).
- 5) Unscrew the handle (3) counterclockwise and make sure the metal piercing shaft (4) goes inside the plastic washer (6).
- 6) Place the body (5) onto the copper pipe (7) and slide the adapter shank (2) as illustrated.
- 7) Screw the bolt (1) all the way by hand, then tighten by 1/2 turn with pliers or adjustable wrench. This will secure the SPNV onto the copper pipe.
- 8) Screw the handle (3) clockwise until the end in order to pierce the copper pipe. Leave the handle in this position until system startup.
- 9) Connect an appropriate length of flexible tubing by using a brass nut (8), plastic ferrule (9) and plastic insert (10).
- 10) Connect the other tube end to filter module entrance (B) using a plastic nut and insert.

Laboratory Tests!

NanoCarb NC-254 Advanced Wide Spectrum Carbon MonoBlock Water Filter has been continuously tested in independent laboratories located around the world.

The information provided herein is only but a summary of actual laboratory results. These results portray the functionality of the NanoCarb NC-254 filter without the use of prefiltration stages.

Your water source may or may not have the same contaminants. Depending on your water source and its clarity, your NanoCarb filter will provide same or varying results for the organic and inorganic removal levels, but rest assured that in terms of the bacteriological removal efficiency, NanoCarb will provide a secure barrier between your water source and your consumption.

Random grouping of laboratory results

Analysis Parameter	Feed Water	Filter Water	MCL Limit	% eff.
Typical Analysis A				
Aerobic germs				
@ 37deg.C unit/ml	2,000,000	8	<10	99.9%
Aerobic germs				
@ 27deg.C unit/ml	750,000	14	<100	99.9%
Total coliforms				
@ 37deg.C unit/100 ml	300,000	0	0	100%
Fecal coliform				
thermo-tolerant @ 44 deg.C	300,000	0	0	100%
Streptococcus				
D group type	10,000	0	0	100%
Bacterial spores				
Sulfate reducing	40,000	0	<1	100%

B. Six month study on two bacteria loaded feed water samples, with analysis every two weeks. Water was drawn from the filters every 3 days to simulate low usage, hence enabling bacteria to have enough time to grow and proliferate. The table below shows the results.

B	Feed Water		Water After Filter	
	Escherichia Coli (UCB/ml)	Enterococcus faecalis (UCB/ml)	Escherichia Coli (UCB/ml)	Enterococcus faecalis (UCB/ml)
07/10/98	513,000	247,000	0	0
21/10/98	1,440,000	117,000	0	0
04/11/98	1,100,000	1,700,000	0	0
18/11/98	2,430,000	650,000	0	0
04/12/98	1,460,000	377,000	0	0
17/12/98	1,080,000	350,000	0	0
06/01/99	190,000	410,000	0	0
19/01/99	963,000	317,000	0	0
04/02/99	850,000	263,000	0	0
18/02/99	3,000,000	280,000	0	0

General laboratory results

1- Inorganic Substances

Cadmium	>	99.00 %
Chromium	>	99.00 %
Copper	>	90.00 %
Nickel	>	89.00 %
Iron	>	99.00 %
Manganese	>	78.00 %
Lead	>	98.00 %
Chlorine residual	>	99.90 %
Turbidity	>	97.00 %

2- Organic Substances

Arsenic	>	98.00 %
Bromodichloromethane	>	99.90 %
Bromoform	>	99.90 %
Benzene	>	99.00 %
Chloroform	>	99.999 %
Dibromochloromethane	>	99.90 %
Tetrachloromethane	>	99.90 %
Trichloroethane	>	99.90 %
Tribromoethane	>	99.90 %
Phenol	>	99.90 %
Trichloroethane 111, 112	>	99.00 %
Tetrachloroethylene	>	99.90 %
Toluene	>	99.90 %
Heptane	>	99.90 %
Alpha - CHC	>	99.00 %
Gamma - CHC (Lindane)	>	99.80 %
Atrazin	>	99.80 %
Simazin	>	99.00 %
Fluorescein	>	99.00 %
Naphtaline	>	99.99 %
Acenaphtaline	>	99.99 %
Fluorene	>	99.98 %
Acenaphtene	>	99.99 %
Benzo(a)pyrene	>	99.73 %
Pyrene	>	99.82 %
DDT	>	99.80 %

3- Microbiological Efficiency

Total germicidal index	100 %
Bacteria Escheria Coli	100 %
Total coliforms	100 %
Total fecal coliforms	100 %
Streptococcus	100 %
Polio virus	> 99.999%